

# INSTALLATION INSTRUCTIONS

## – Server Back-Up PC Board –

### For PAW-SERVER-PKEA Type PC Board

Model No.

	<b>PCB Type</b>
	PAW-SERVER-PKEA V4.4

For installation in the following indoor units

		2.8 kW	3.2 kW	4.5 kW	5.0 kW
<b>PKEA</b>	<b>Wall-mounted Indoor Unit</b>	CS-E9PKEA	CS-E12PKEA	CS-E15PKEA	CS-E18PKEA
	<b>Outdoor Unit</b>	CU-E9PKEA	CU-E12PKEA	CU-E15PKEA	CU-E18PKEA

Refrigerant R410A is used in the outdoor units.



## **Main features of PAW-SERVER-PKEA Type PC Board**

- Each PAW-SERVER-PKEA PCB can handle two PKEA indoor units
- Cascade management
  - Master/Slave configuration
  - Performance enhancement through Slave unit activation
  - Master/Slave changeover in set intervals
- Back-up functionality
  - In case of an alarm, the other unit becomes the Master
- Server room overheating prevention
- DIP switch settings
  - Energy saving mode
  - Two different third-party BMS management modes

For more details, please see “Operation Logic” on page 8 of this document.

## For your safety

Read the following instructions carefully, and carry out secure installation and electrical work. The precautions given in this manual consist of specific “Warnings” and “Cautions”. They provide important safety-related information. Be sure to strictly observe all safety procedures. The labels and their meanings are as described below.

	<b>Warning</b>	This symbol refers to a hazard or unsafe procedure or practice that can result in severe personal injury or death.
	<b>Caution</b>	This symbol refers to a hazard or unsafe procedure or practice that can result in personal injury or product or property damage.

After installation is completed, perform a test run to check for operating trouble. Explain operating procedures to the customer following the CONNECTION SCHEME and the OPERATION LOGIC.

	<b>Warning</b>
	<ul style="list-style-type: none"> <li>• Be sure to arrange installation by the dealer where the system was purchased or by a professional installer. Electric shock or fire may result if an inexperienced person performs any installation or wiring procedures incorrectly.</li> </ul>
	<ul style="list-style-type: none"> <li>• Be sure that this unit is securely installed in accordance with these “Instructions for the Electrical Installer”. Electric shock or fire may result if any installation or wiring procedures are incorrectly performed.</li> </ul>
	<ul style="list-style-type: none"> <li>• Only a qualified electrician should attempt to connect this system, in accordance with the instructions in this manual. Insufficient electrical circuit capacity or incorrect installation may cause electric shock and fire.</li> </ul>
	<ul style="list-style-type: none"> <li>• Use the specified cables for the electrical connections, and connect the cables securely. Run and fasten the cables securely so that external forces or pressure placed on the cables will not be transmitted to the connection terminals. Overheating or fire may result if connections or attachments are not secure.</li> </ul>
	<ul style="list-style-type: none"> <li>• Depending on the installation conditions and location, an earth leakage breaker may be required. If an earth leakage breaker is not installed, there is a danger of electric shock or fire.</li> </ul>
	<ul style="list-style-type: none"> <li>• The installation location requires the use of a circuit breaker. Failure to use a circuit breaker may result in electric shock or fire.</li> </ul>
	<ul style="list-style-type: none"> <li>• Circuit breaker must be incorporated in the fixed wiring in accordance with the wiring regulations. The circuit breaker must be an approved 10-16 A, having a contact separation in all poles.</li> </ul>

	<b>Caution</b>
	<ul style="list-style-type: none"> <li>• Ground yourself to discharge static electricity before performing any wiring.</li> </ul>

## 1 Parts supplied

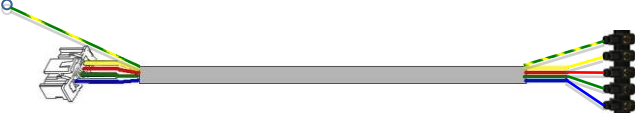
- n. 1 PAW-SERVER-PKEA 
- n. 2 CAB-SERV, indoor unit connectors 

## 2 Connection scheme (all items inside the server room)

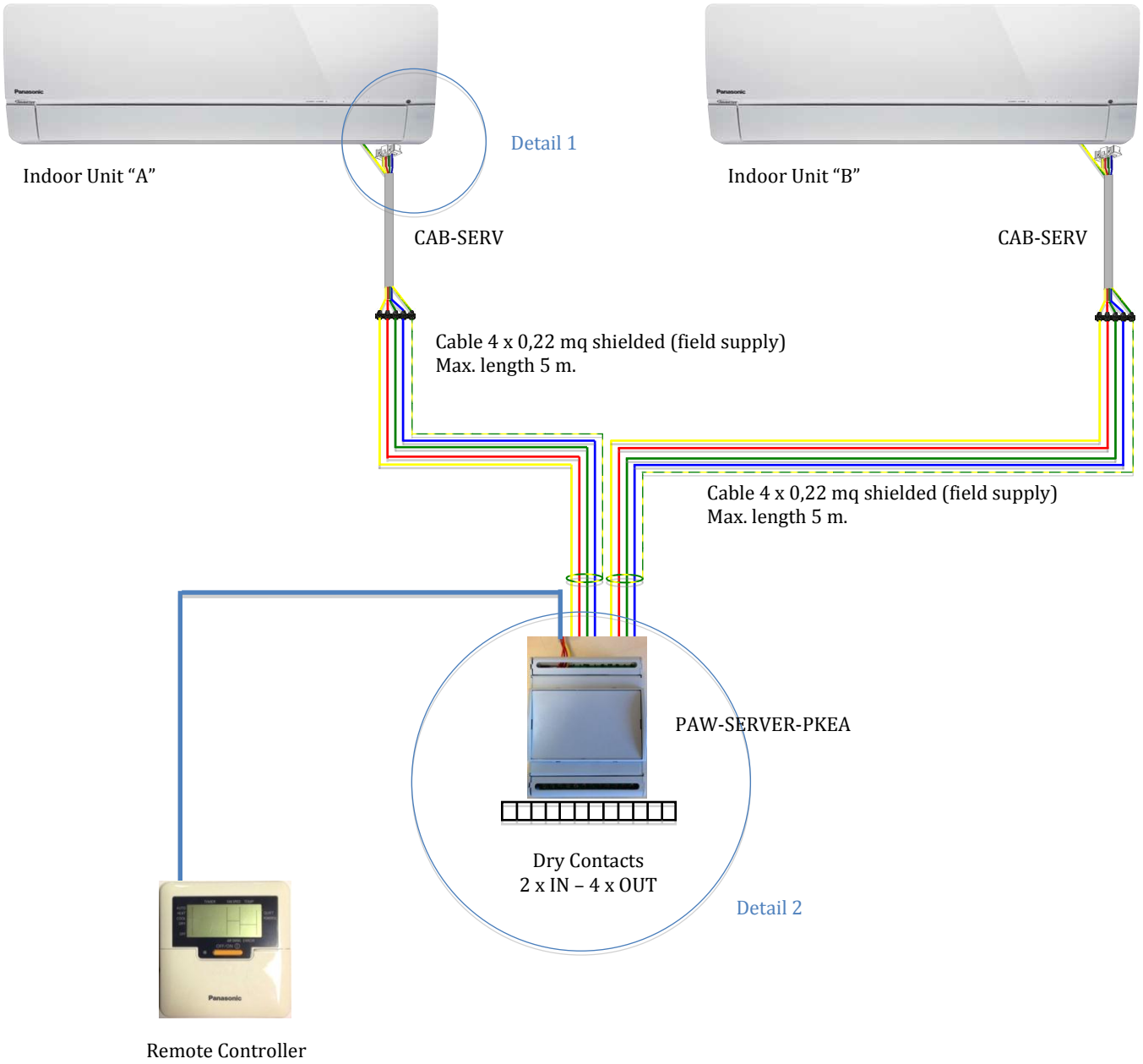

## Detail 1 (for each indoor unit): how to connect CAB-SERV to indoor unit PCB

- 1) Remove the front panel of the indoor unit and the cable box cover (pic. 1).
- 2) Lift the terminal block (pic. 2).

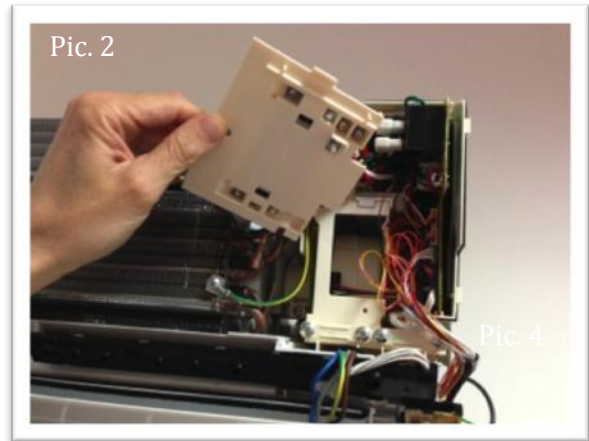
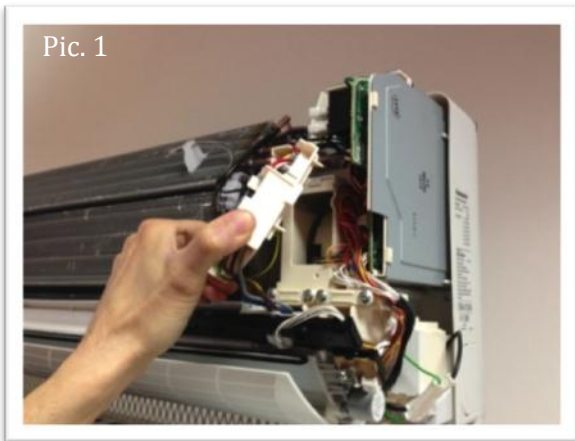

- 3) Insert the CAB-SERV cable from the rear of the indoor unit into the trough-hole toward the front side, just near the indoor unit PC Board (pic. 3, 4).

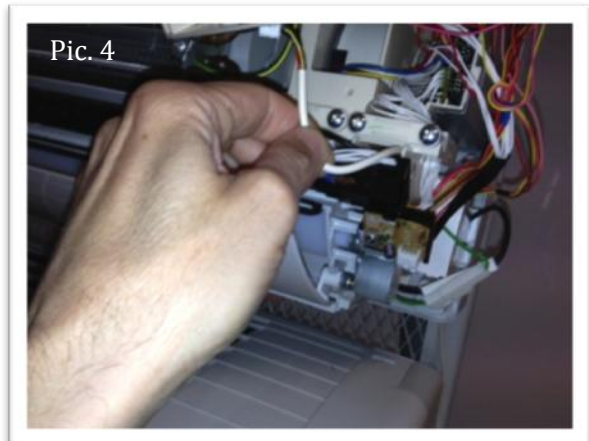

- 4) Insert the CAB-SERV connector into the CN-CNT plug on the Indoor PC Board (pic. 5, 6).

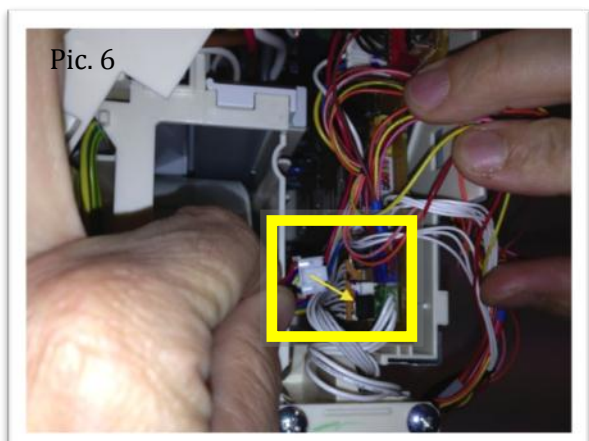
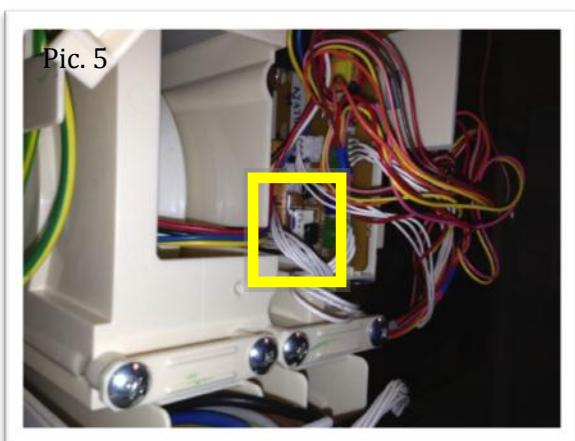

- 5) Connect the ground wire of CAB-SERV on a ground tab available on the indoor unit.

## Detail 2

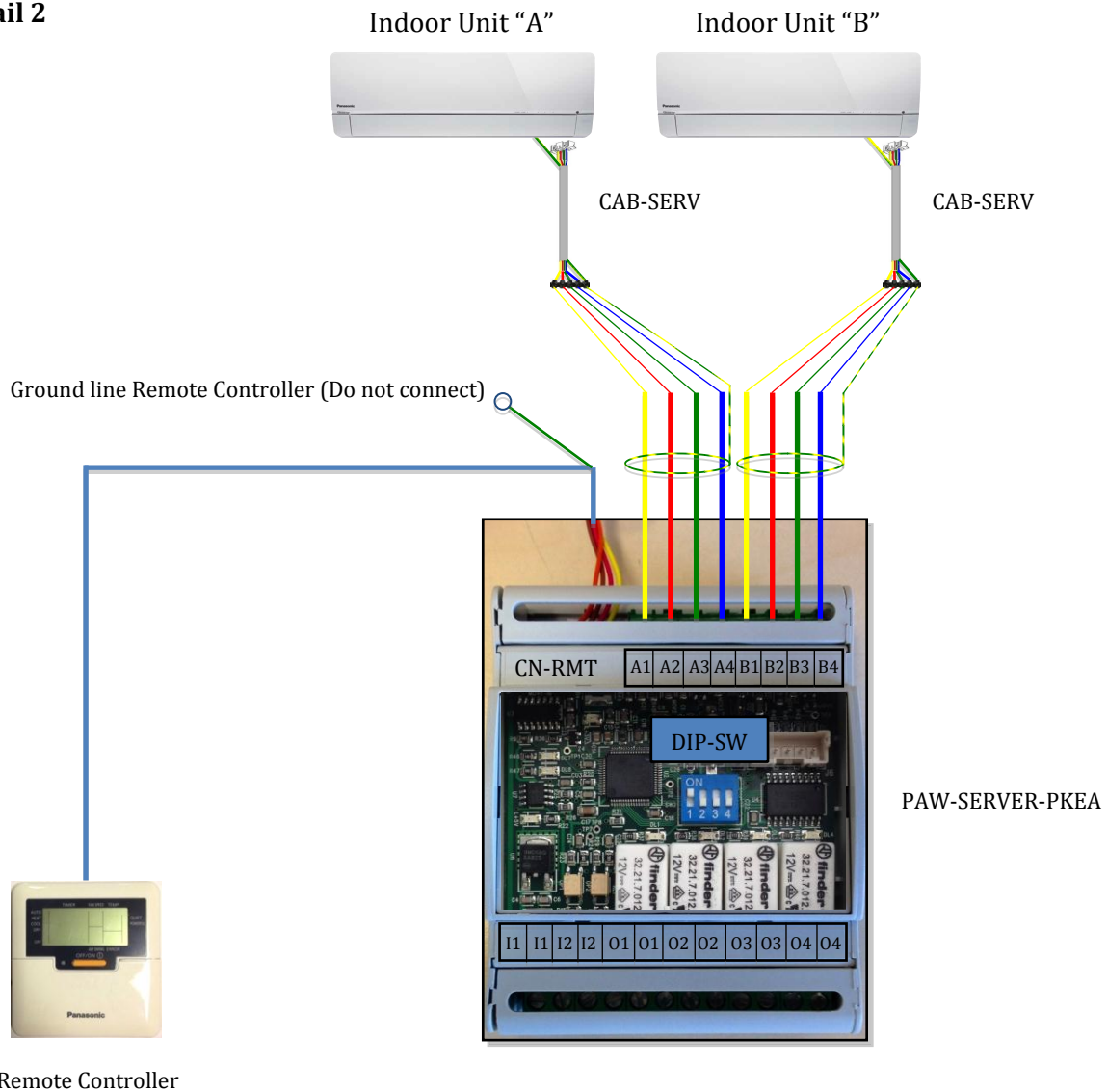

Connect the Remote Controller to the CN-RMT plug on the top-left side of the PAW-SERVER-PKEA.

The ground line of the Remote Controller cable has NO connection (you may also cut the wire).

Connect the 4-wire cable between PAW-SERVER-PKEA and the unit "A" and "B" paying attention to the terminal labels:

A1 -> YELLOW wire of CAB-SERVER, indoor unit "A" (Ground);  
 A2 -> RED wire of CAB-SERVER, indoor unit "A" (+12 Vdc);  
 A3 -> GREEN wire of CAB-SERVER, indoor unit "A" (Tx signal);  
 A4 -> BLUE wire of CAB-SERVER, indoor unit "A" (Rx signal);  
 Shield (not connected to PAW-SERVER-PKEA) -> Green wire of CAB-SERVER

B1 -> YELLOW wire of CAB-SERVER, indoor unit "B" (Ground);  
 B2 -> RED wire of CAB-SERVER, indoor unit "B" (+12 Vdc);  
 B3 -> GREEN wire of CAB-SERVER, indoor unit "B" (Tx signal);  
 B4 -> BLUE wire of CAB-SERVER, indoor unit "B" (Rx signal);  
 Shield (not connected to PAW-SERVER-PKEA) -> Green wire of CAB-SERVER



In the lower part of the PAW-SERVER-PKEA you can find 2 INPUT and 4 OUTPUT Dry Contacts. OUTPUT Dry Contacts can handle max. 48 Volt - 3 Ampere.  
Here are the functions available:

**INPUT (NO Voltage):**

- (I1 - I1) -> Available only when Dip-Switch n. 3 is ON.  
Short Circuit -> Set Unit "A" ON.  
Open Circuit -> Set Unit "A" OFF.
- (I2 - I2) -> Available only when Dip-Switch n. 3 is ON.  
Short Circuit -> Set Unit "B" ON.  
Open Circuit -> Set Unit "B" OFF.

**OUTPUT (Max. 48 Volt - 3 Ampere):**

- (O1 - O1) -> Always available.  
Short Circuit -> ON state of unit "A".  
Open Circuit -> OFF state of unit "A".
- (O2 - O2) -> Always available.  
Short Circuit -> ON state of unit "B".  
Open Circuit -> OFF state of unit "B".
- (O3 - O3) -> Always available.  
Short Circuit -> NO Alarm unit "A".  
Open Circuit -> ALARM unit "A".
- (O4 - O4) -> Always available.  
Short Circuit -> NO Alarm unit "B".  
Open Circuit -> ALARM unit "B".



**Connection example:**

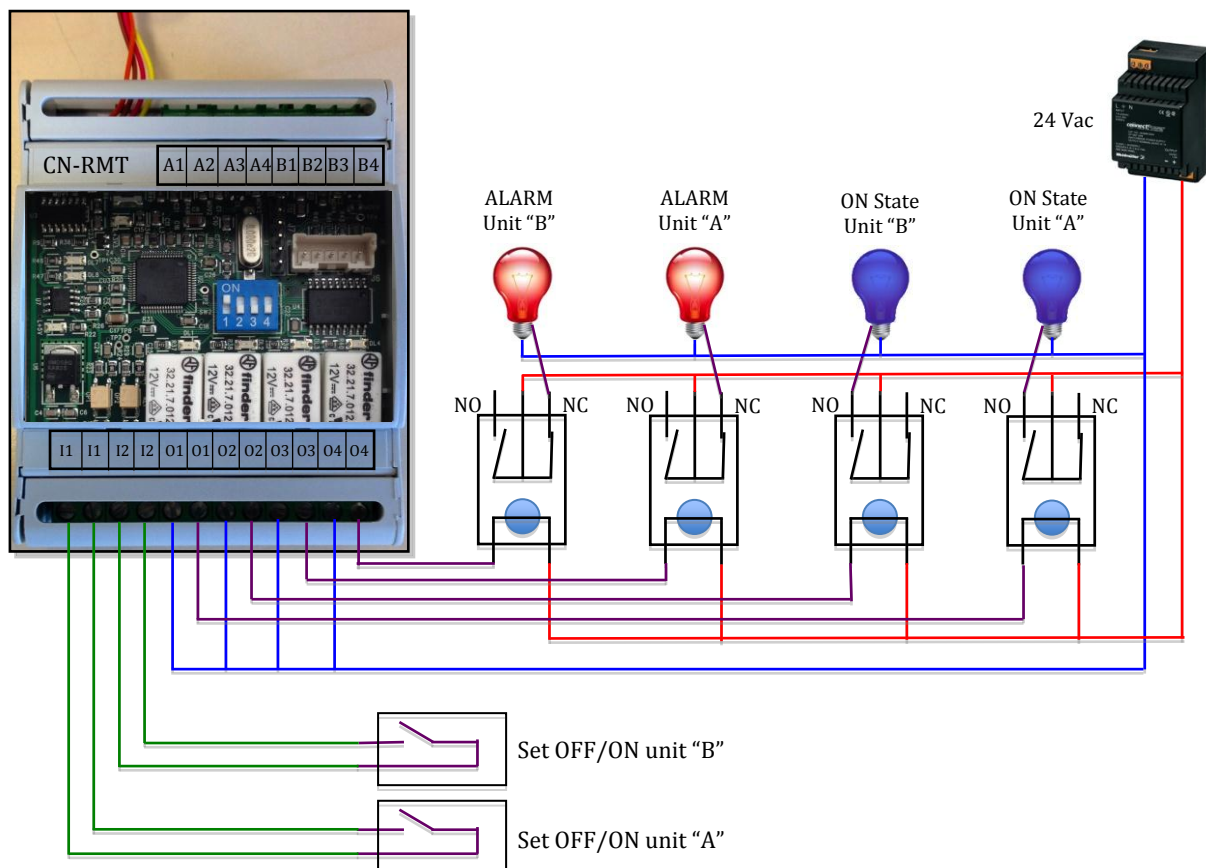

The PAW-SERVER-PKEA can handle two Units of PKEA series, for Computer Room installations. Operation parameters are set by the Remote Controller for both units.

### - Cascade Management:

PAW-SERVER-PKEA handles the units as follow described:

- One unit is Master and the other one is Slave (at first power supply unit “A” will be Master).
- When ON state is set on the Remote Controller, only the Master unit starts.
- Room temperature is detected by the Master unit.
- Every 12 hours working interval, Slave becomes Master.
- Slave unit will switch to ON in these cases:
  - COOLING/DRY Mode:  $(\text{Room Temperature} - \text{Set Temperature}) \geq 2\text{ }^{\circ}\text{C}$
  - HEATING Mode:  $(\text{Set Temperature} - \text{Room Temperature}) \geq 5\text{ }^{\circ}\text{C}$

Slave unit will switch OFF in these cases:

- COOLING/DRY Mode: Room Temperature = Set Temperature
- HEAT Mode: Room Temperature = Set Temperature



### - Back-up:

If an alarm occurs on one unit, the other one becomes Master. When the failure is over, the repaired unit will become Master.

### - Server Room Overheating prevention:

If indoor temperature rises above 28 °C, both indoor unit alarms will be activated.

### - Dip Switch functions:

Inside the PAW-SERVER-PKEA, removing the central cover, you find 4 dip-switches.

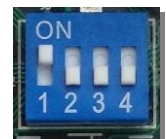

- Dip-Switch n. 1 is for service only. It must be set to ON.
- Dip-Switch n. 2 enables “Energy Saving Mode”.  
If room temperature is between 8 °C and 18 °C, the units will be OFF (indoor temperature is checked by the Master unit).
- Dip-Switch n. 3 enables “Third Party BMS Management: mode “A” (remote controller DISABLED)”.

#### SETTING PROCEDURE

1. Switch ON the unit and set up operation parameters (mode, set temperature, fan speed, vane position)
2. Set to ON Dip Switch n. 3

From now on the PAW-SERVER-PKEA stores the functioning parameters (mode, set temperature, fan speed, vane position) and **ignores the Remote Controller**.

Only ON/OFF state will be possible through the dry contacts I1, I2 (you can find them on the lower part of the PAW-SERVER-PKEA).

Third party BMS can just operate through dry contacts and there is no way to read or modify the system parameters set by the Remote Controller.



- Dip-Switch n. 4 enables “**Third Party BMS Management: mode “B” (remote controller ENABLED)**”.

#### SETTING PROCEDURE

3. Switch ON the unit and set up operation parameters (mode, set temperature, fan speed, vane position)
4. Set to ON Dip Switch n. 4

From now on ON/OFF state will be possible through the dry contacts I1, I2 (you can find them on the lower part of the PAW-SERVER-PKEA).

#### **Remote controller can operate normally.**

Improper setting to ON of both Dip Switch n. 3 and 4, will be handled as Dip Switch n. 3 ON.

Third party BMS can just operate through dry contacts and there is no way to read or modify the system parameters set by the Remote Controller.

**Note:** Service functions (RC Reset, AC Reset, Check) are not available through PAW-SERVER-PKEA. For Service Functions connect the remote controller directly to the indoor unit.  
Emergency button on the indoor unit is overridden by Remote Controller settings.

4

## Outer dimensions

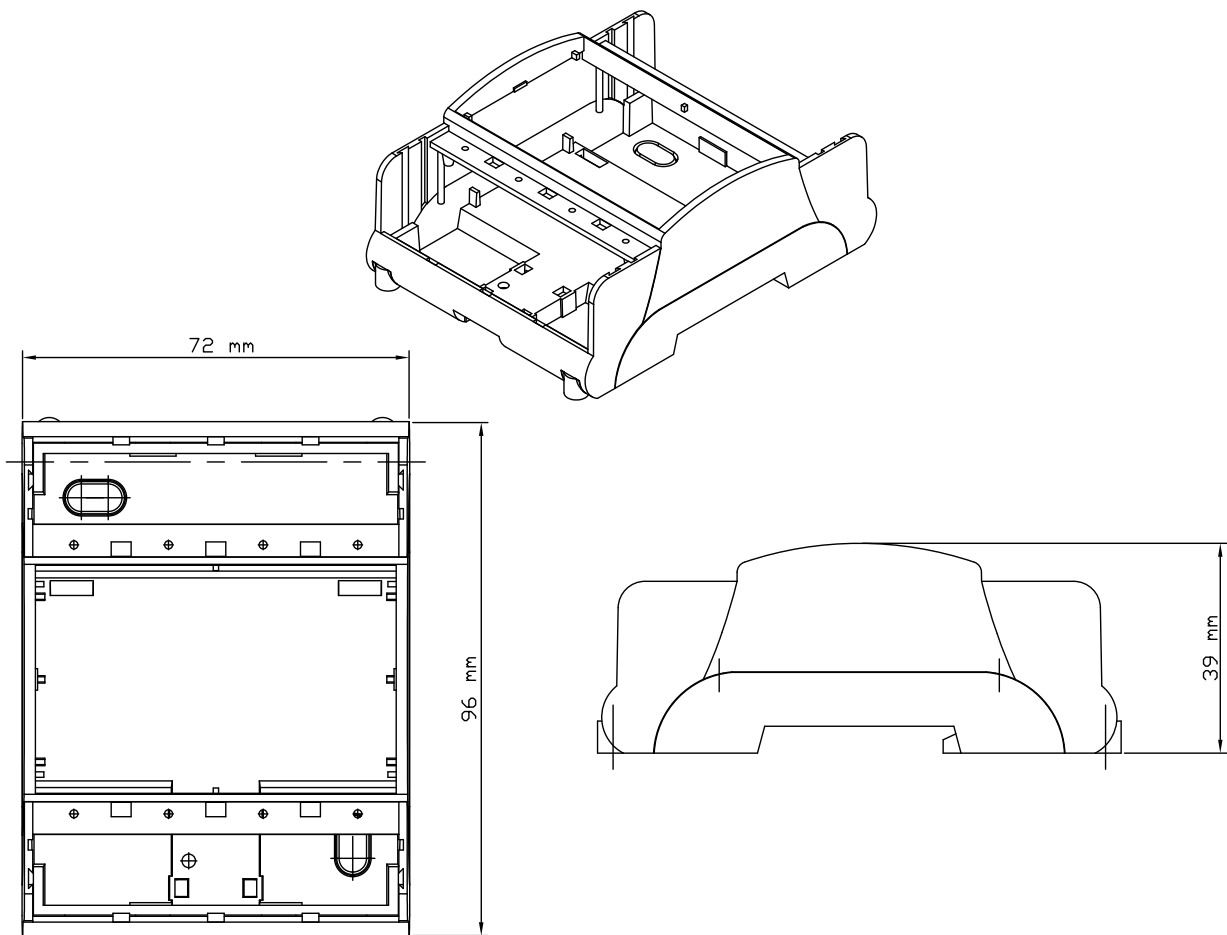

PAW-SERVER-PKEA can be installed in a standard DIN rail.

